



KEY FEATURES

- Designed for headphone, speaker & microphone test
- Fully integrated with APx500 audio measurement software
- Two-channel power amplifier with 20 dB of fixed gain from DC to 100 kHz
- Integrated current-sense resistors for impedance measurements
- ± 0.08 dB frequency response (10 Hz to 20 kHz; DC-coupled)
- 134 dB signal-to-noise ratio
- Integrated microphone power supplies support phantom power and CCP
- TEDS-capable microphone inputs

A new level of performance in electro-acoustic test

Developed for designers and production test engineers seeking clear insight into the behavior of their electro-acoustic devices, the **APx1701 Transducer Test Interface** is an APx500 software-controlled test accessory that combines instrument-grade amplification with signal conditioning for pre-polarized measurement microphones, and phantom power for professional microphones.

Market-leading performance

The APx1701 is a PC-controlled test accessory providing 20 dB of fixed-gain amplification from DC to 100 kHz. Voltage taps across integrated current-sense resistors in the amplifier outputs enable easy impedance curve measurements. The amplifier channels are configured independently, with power ratings up to 100 W for a single channel into 8 Ω . In the frequency range of 10 Hz to 20 kHz, the system's residual THD+N is ≤ -105 dB (80 kHz BW) and frequency response is ± 0.08 dB (DC-coupled). Signal-to-noise ratio is an industry-leading 134 dB.

For microphones, either as measurement mics or as the device under test (DUT), the APx1701 is equipped with pairs of balanced and unbalanced microphone inputs. The balanced inputs include switchable +48 V phantom power, while the unbalanced inputs support switchable CCP (Constant Current Power) and are TEDS-capable (Transducer Electronic Data Sheet).

Calibrated instrumentation

Whether in a lab characterizing a design's performance or conducting QA-testing on a production line to ensure products meet their specifications, confidence in the resulting measurements is key. Like the APx500 Series analyzers it is designed to complement, the APx1701 is a calibrated instrument under ISO / IEC 17025:2005 and all new units ship with an Accredited Calibration. Calibration provides documented and traceable verification that instruments meet or exceed all of their published specifications.

APx Series Audio Analyzers



APx515
2-channel audio analyzer



APx52x Series
Modular 2- & 4-channel performance audio analyzers



APx555
High-performance, modular 2-channel audio analyzer



APx58x Series
8- & 16-channel modular audio analyzers

Loudspeaker, headphone and microphone testing

From fundamental test set-ups such as the loudspeaker scenario shown at right to more advanced situations such as headphone impedance testing or microphone intermodulation distortion (IMD) measurement, the APx1701 is an ideal accessory to any APx500 Series analyzer.

Additionally, its integration into APx500 audio measurement software means new and existing APx users alike can take advantage of the software's highly-intuitive user interface. From a practical perspective, all APx audio analyzers use the same software, making tests and results easier to share between R&D and production facilities anywhere in the world.

For example, a test designer using an APx525 can create a production test sequence and email it to a contract manufacturer whose APx515 will run the project natively. Performing quality assurance on the production line, the APx515 operator can save a recording of the actual output of a device under test and email it (along with the 515's settings) in a single project back to Engineering for further analysis.

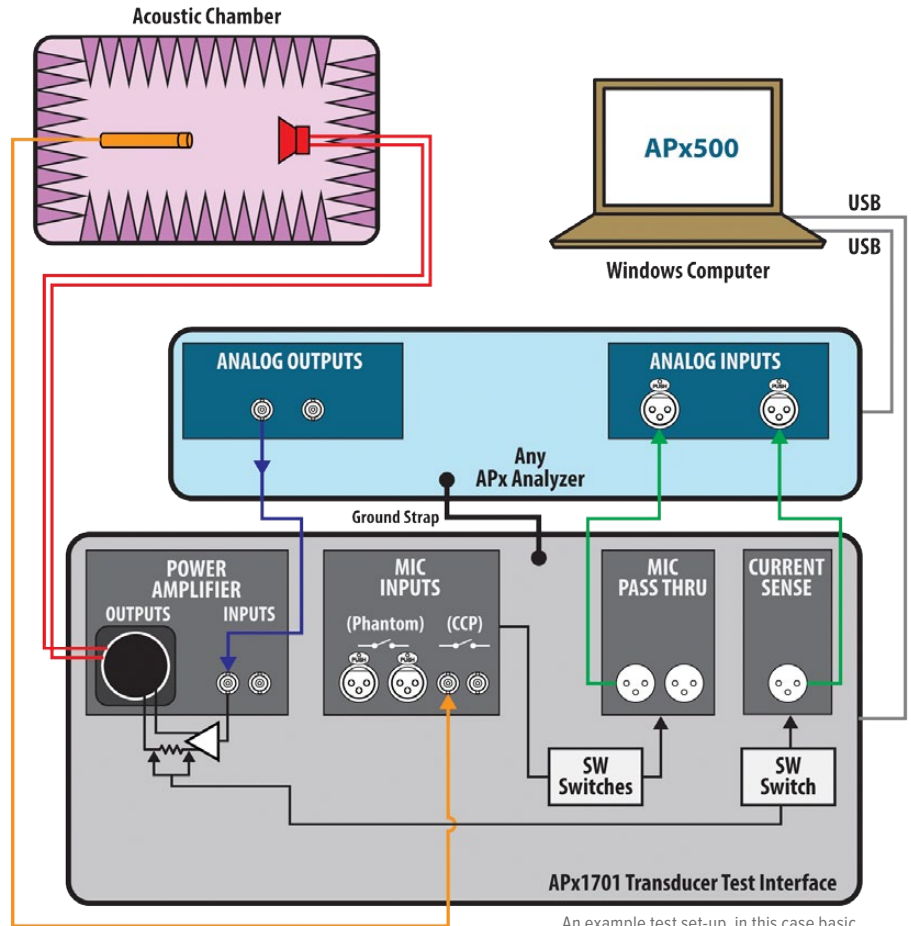

An example test set-up, in this case basic speaker testing, with an APx Series analyzer and the APx1701. The system is equally well-suited to headphone and microphone measurement.

Integrated analog, digital and electro-acoustic test

The increasing complexity of audio devices (wireless Bluetooth™ speakers and active noise-canceling headphones, for example) is driving ever-more complicated test scenarios, especially if engineers have to repeatedly switch measurement instruments.

As an electro-acoustic test accessory, the APx1701 is directly integrated with APx500 audio measurement software and, when paired with any APx Series analyzer, provides an integrated platform capable of evaluating the performance of electro-acoustic devices as well as their analog and digital components.

KEY SPECIFICATIONS

AMPLIFIER PERFORMANCE

Power Ratings

100 W (1 channel in 8 Ω, 10 Hz to 50 kHz)
 95 W (1 channel in 8 Ω, 50 kHz to 100 kHz)
 60 W (1 channel in 4 Ω, 10 Hz to 50 kHz)
 55 W (1 channel in 4 Ω, 50 kHz to 100 kHz)
 30 Vrms (2 channels in ≥16 Ω)

Frequency Range

DC to 100 kHz

Frequency Response

±0.08 dB (10 Hz to 20 kHz, DC-coupled)
 ±0.30 dB (20 kHz to 50 kHz)
 ±0.80 dB (50 kHz to 100 kHz)

Voltage Gain

20.0 dB [x10]

Residual Noise

≤7.5 μVrms (22 kHz BW)
 ≤13 μVrms (80 kHz BW)

Signal-to-Noise Ratio

≈134 dB (ref 30 Vrms output)

Output Impedance

≈0.13 Ω (0.1 Ω current sense resistor in series with the - output terminal)

Residual THD+N

≤ -105 dB, 10 Hz to 20 kHz (80 kHz BW)

MICROPHONE INPUTS

Configuration

Balanced and Unbalanced (2 each)

Balanced Mic Inputs

2 female XLR
 Switchable +48 V phantom power

Unbalanced Mic Inputs

2 BNC
 Switchable CCP (4 mA, +24 V)
 TEDS-capable

Maximum Input

10 Vpk Balanced
 5 Vpk Unbalanced

Residual Noise

Determined by analyzer; inputs passively switched

Input Crosstalk

≤ -80 dB + 1 μV to 20 kHz



Accredited by A2LA
 under ISO/IEC: 17025
 for equipment calibration